

FICHA TÉCNICA

Referencias: MHGR-RM3518.

Denominación comercial: grapadora neumática para cartón G3518.



Características:

- Color: rojo.
- Tipo: neumática.
- Peso: 2,650 kilos.
- Presentación: caja.
- Aplicaciones: embalajes de cartón.
- Presión de trabajo: 4/8 bar/60-120 psi.
- Aplicaciones: embalajes de cartón.
- Capacidad del cargador: 100 grapas.
- Grapa compatible: grapa latonada de 35 mm de ancho y 18 mm de alto.

Despiece:

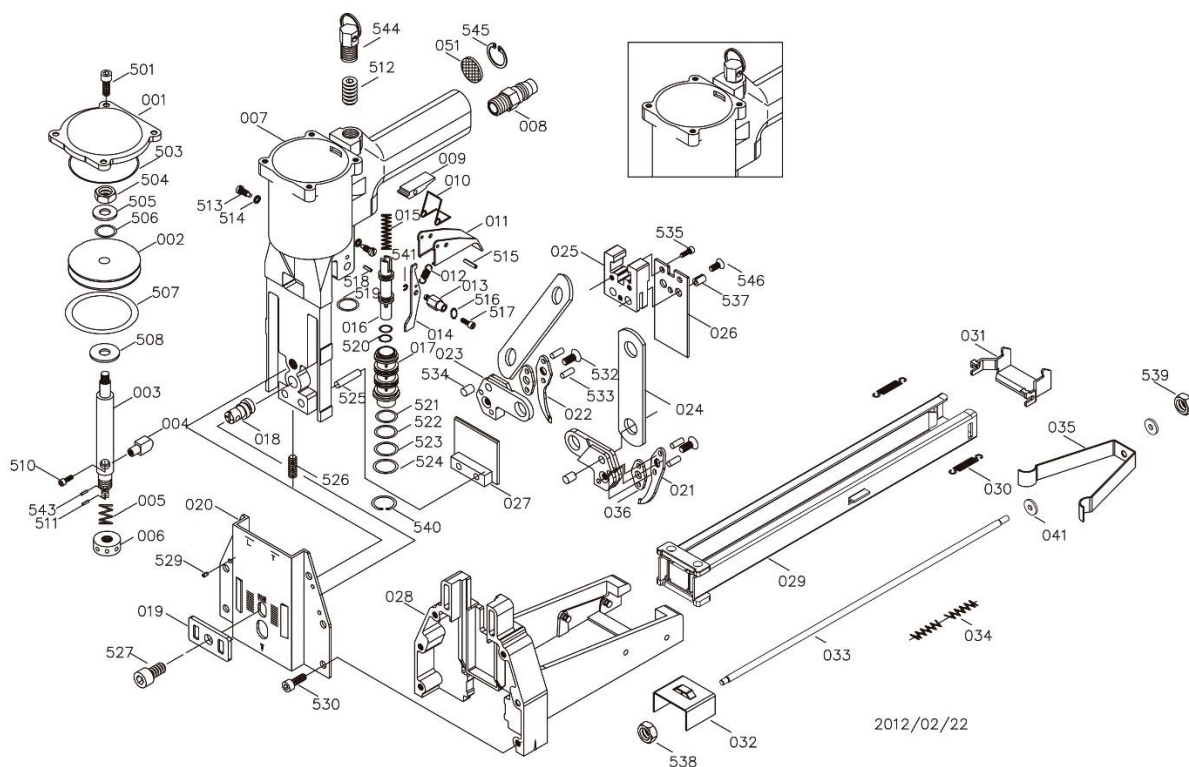

NUM. REF.	DESC.	NUM. REF.	DESC.		
001	A01200110	CAP	504	BAD02061	HEX.NUT
002	A02800201	PISTON	505	BAE06094	WASHER
003	A02800301	PISTON ROD	506	BAB017076	O-RING
004	A00100401	BLOCK	507	BAB057476	O-RING
005	A00100501	SPRING	508	A00104101	WASHER
006	A00100601	COLLAR	510	BAC0604102	HEX.SOC.HD.BOLT
007	ADCS-P31	BODY UNIT	511	BAA025014	SPRING PIN
008	A00100803	AIR PLUG	512	BAC0312122	HEX.SOC.HDLESS.BOLT
009	A00100902	BLOCK	513	A00104401	TRIGGER SCREW
010	A00101001	SPRING	514	BAE01042	SPRING WASHER
011	A00101101	TRIGGER	515	BAA030020	SPRING PIN
012	A00101201	SPRING	516	BAE02042	OUTSIDE TEETH WASHER
013	A00101301	ROD	517	BAC0404102	HEX.SOC.HD.BOLT
014	A00101402	TRIGGER'S CONTROL	518	BAA030010	SPRING PIN
015	A00101501	SPRING	519	BAB017124	O-RING
016	A00101601	VALVE	520	BAB017076	O-RING
017	A00101702	TUBE	521	BAB016145	O-RING
018	A00101801	ADJUSTING ROD	522	BAB016150	O-RING
019	A00101901	ADJUSTING PLATE	523	BAB016155	O-RING
020	A01102501	FRONT PLATE	524	BAB016160	O-RING
021	A00102102	RIGHT TEETH	525	A00104701	ROD
022	A00102202	LEFT TEETH	526	BAC0306142	HEX.SOC.HDLESS.BOLT
023	A00102301	TEETH SEAT	527	BAC0608162	HEX.SOC.HD.BOLT
024	A00102401	PLATE	529	BAA030010	SPRING PIN
025	A00102502	BLOCK	530	BAC0605142	HEX.SOC.HD.BOLT
026	A00102605	DRIVER	532	A00106201	HEX.SOC.FLAT COUNTER
027	A00102703A	COVER UNIT			SUNK HD.SCREW
028	A01101403A	MAGAZINE SEAT	533	A00104501	PIN
029	HA-19-35-P2C	MAGAZINE	534	A00104602	PIN
030	A01102403	SPRING	535	BAC0604102	HEX.SOC.HD.BOLT
031	A01102201	BRACKET	537	BAA060016-R	SPRING PIN
032	A01101801	PUSHER	538	BAD01051	LOCK NUT
033	A01102002	ROD	539	BAD01051	LOCK NUT
034	A01102101	SPRING	540	BAF22002	C-RING
035	A01101901	STOPPER	541	BAF10252	E-RING
036	A00105001	WASHER	543	A00104901	PLASTIC PIN
041	A01103301	WASHER	544	C0011201A	COUNTER BALANCE HANGER
051	BAI1401	SILENCER	545	BAF22002	C-RING
501	BAC0604142	HEX.SOC.HD.BOLT	546	BAC0204062	HEX.SOC.FLAT COUNTER
503	BAB017537	O-RING			SUNK HD.SCREW

Consumible compatible: grapa latonada de 35 mm de ancho y 18 mm de alto.



Valsay Sistemas de Embalaje S.L.
 Pol. Industrial La Nava, Calle A-9
 31300. Tafalla, Navarra
 ☎ 948 71 23 71
 ✉ valsay@valsay.com
 🌐 www.valsay.com

